

K747



450 nits



IP66



Fanless



WiFi



RFID



Features

- 15" True-Flat PCAP Touch
- Intel Bay Trail Processor
- Front IP66, Rear IP20
- Fanless and Silent
- Isolated DI/DO, RS232 & RS232/422/485 by Terminal Block with Strain Relief
- RFID/ WiFi + BT Available
- Front Key-Secured Lock for USB & Power Switch
- Best Panel Mount IPC Solution for Automation Application



As labor costs are increasingly growing, companies in the automation industry are looking to make their factories smarter through improving efficiency, lowering human labor, and continuing to guarantee high product quality. Flytech provides a wide range of industrial touch Panel PC products in different form factors, high brightness displays, and customizable high performance hardware configurations that are designed and certified to work under harsh environments and various automation applications.

K747

Industrial Automation Touch Panel Mount PC

FLYTECH

www.flytech.com

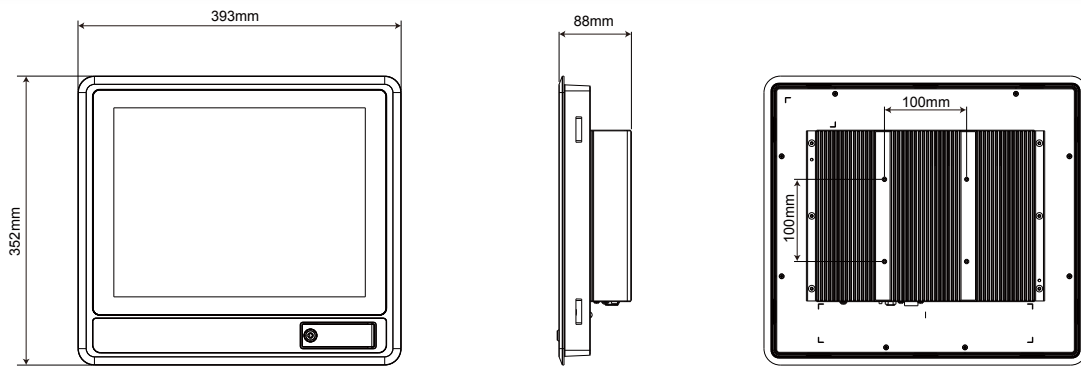

Specification

Motherboard	Type Processor Chipset System Memory Memory Socket Graphic Engine	D35 Intel Bay Trail CPU Celeron J1900, Quad Core 2G/2.41G CPU Integrated DDR3L 1333MHz (max. 8G) 1x SO-DIMM Intel HD Graphic
LCD Touch Panel	LCD Size Brightness Resolution Touch Screen	15" (4:3 ratio) 450 nits 1024 x 768 True-Flat PCAP Touch
Storage Device	HDD/ SSD Flash Memory	1x 2.5" SATA 1x mSATA 32G
Expansion	Mini PCI-E Socket	2 (Full & Half-size)
External I/O Ports	USB Serial Port LAN Audio Jack VGA DVI GPIO Power Button	1x USB2.0 Front, 4x USB2.0 Rear 2x RS232, 1x RS232/422/485 (Isolation, terminal block) 2x RJ45 1x Line-out, 1x Mic-in 1x DB15 1x DVI-D 4x DI/ 4x DO (Isolation, terminal block) 1x Front, 1x Rear
Power	Wide Range Power Input Connector	12-48V 3-pole terminal block
Peripheral (Option)	WiFi + BT RFID	802.11 b/g/n WLAN card + BT 4.0 1
Certificate	EMC & Safety	FCC Class B, CE Mark
Environment	Ventilation Dust & Water Proof Operating Temperature Storage Temperature Humidity Operating Vibration Operating Shock	Fanless Front IP66, Rear IP20 0°C ~ 50°C (32°F ~ 122°F) (Still Air) -20°C ~ 60°C (-4°F ~ 140°F) 10% ~ 95% @40°C, non-condensing 5Grms random, 5 ~ 500Hz (1Grms with HDD) (EN 60068-2-6) 20Grms random, 11ms (EN 60068-2-27)
Dimension (WxDxH)		393 x 88 x 352 mm (15.5" x 3.5" x 13.8")
Weight		5.8 kg (12.8 lbs)
Mounting		Panel Mount, VESA Mount 100 x 100
OS Supported		Windows 7 (32/64bit), Windows 8.1 (32/64bit), Windows 10 (32/64bit), Linux

Taiwan - Headquarters

No.168, Sing-ai Rd., Neihu District,
Taipei City 11494, Taiwan, R.O.C.
Tel: 886-2-8791-4988
Fax: 886-2-8791-4966
E-mail: sales@flytech.com.tw
www.flytech.com

U.S.A. - California

728 Charcot Ave, San Jose,
CA 95131, U.S.A
Tel: 1-510-257-5180
Fax: 1-510-257-5181
E-mail: sales@flytech.com

China - Shanghai

3F Building 39, No. 333 Qin Jiang Rd.,
Shanghai 200233, P.R.China
Tel: 86-21-5426-1555
Fax: 86-21-5426-1001
E-mail: sales@flytech.com.cn
www.flytech.com.cn

China - Hong Kong

Room 01, 6/F, Block A, Tonic Industrial
Centre, 26 Kai Cheung Road, Kowloon
Bay, Kowloon, Hong Kong.
Tel: 852-3525-5800
Fax: 852-2751-7447
E-mail: sales@flytech.com.hk