

K735



IP66



Fanless



WiFi



RFID

Features

- 10.1" True-Flat PCAP Touch
- Intel Bay Trail Processor
- Front IP66, Rear IP20
- Fanless and Silent
- RFID/ WiFi + BT Available
- Front Key-Secured Lock for USB & Power Switch
- Best Panel Mount IPC Solution for Automation Application



As labor costs are increasingly growing, companies in the automation industry are looking to make their factories smarter through improving efficiency, lowering human labor, and continuing to guarantee high product quality. Flytech provides a wide range of industrial touch Panel PC products in different form factors, high brightness displays, and customizable high performance hardware configurations that are designed and certified to work under harsh environments and various automation applications.

K735

Industrial Automation Touch Panel Mount PC

FLYTECH
www.flytech.com

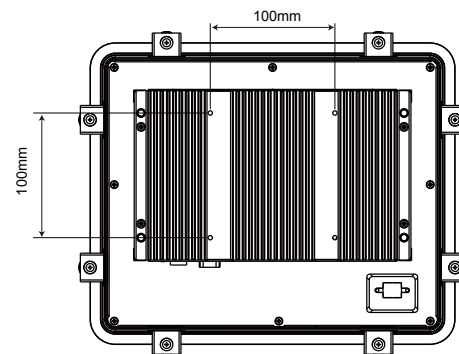
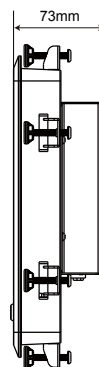
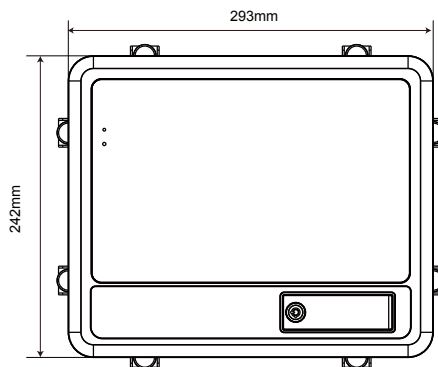

Specification

Motherboard	Type Processor Chipset System Memory Memory Socket Graphic Engine	D36 Intel Bay Trail CPU Celeron J1900, Quad Core 2G/2.41G CPU Integrated DDR3L 1333MHz (max. 8G) 1x SO-DIMM Intel HD Graphic
LCD Touch Panel	LCD Size Brightness Resolution Touch Screen	10.1" (16:9 ratio) 200 nits 1280 x 800 True-Flat PCAP Touch
Storage Device	HDD/ SSD Flash Memory	1x 2.5" SATA SATA Slim SSD 8G/ 16G/ 32G/ 64G (Option)
Expansion	Mini PCI-E Socket	1
External I/O Ports	USB Serial Port LAN VGA Power Button	1x USB3.0, 4x USB2.0 3x RJ48 (with DB9 convert cable) 1x RJ45 1x DB15 1x Front, 1x Rear
Audio	Internal Speaker	2x 2W
Power	Power Adapter Connector	65W / 19V 4-pole DIN (with latch)
Peripheral (Option)	WiFi + BT RFID	802.11 b/g/n WLAN card + BT 4.0 (Option) (either one with 2nd LAN) 1 (Option) (either one with 2nd LAN)
Certificate	EMC & Safety	FCC Class A, CE Mark, LVD
Environment	Ventilation Dust & Water Proof Operating Temperature Storage Temperature Humidity Operating Vibration Operating Shock	Fanless Front IP66, Rear IP20 0°C ~ 35°C (32°F ~ 95°F) (Still Air) -20°C ~ 60°C (-4°F ~ 140°F) 20% ~ 85% RH non-condensing 5Grms random, 5 ~ 500Hz (1Grms with HDD) (EN 60068-2-6) 20Grms random, 11ms (EN 60068-2-27)
Dimension (WxDxH)		293 x 73 x 242 mm (11.5" x 2.9" x 9.5")
Weight		2.9 kg (6.4 lbs)
Mounting		Panel Mount, VESA Mount 100 x 100
OS Supported		Windows 7 (32/64bit), Windows 8.1 (32/64bit), Windows 10 (32/64bit), Linux

Taiwan - Headquarters

No.168, Sing-ai Rd., Neihs District,
Taipei City 11494, Taiwan, R.O.C.
Tel: 886-2-8791-4988
Fax: 886-2-8791-4966
E-mail: sales@flytech.com.tw
www.flytech.com

U.S.A. - California

728 Charcot Ave, San Jose,
CA 95131, U.S.A
Tel: 1-510-257-5180
Fax: 1-510-257-5181
E-mail: sales@flytech.com

China - Shanghai

3F Building 39, No. 333 Qin Jiang Rd.,
Shanghai 200233, P.R.China
Tel: 86-21-5426-1555
Fax: 86-21-5426-1001
E-mail: sales@flytech.com.cn
www.flytech.com.cn

China - Hong Kong

Room 01, 6/F, Block A, Tonic Industrial
Centre, 26 Kai Cheung Road, Kowloon
Bay, Kowloon, Hong Kong.
Tel: 852-3525-5800
Fax: 852-2751-7447
E-mail: sales@flytech.com.hk